

# CESNET Technical Report 6/2009

## All-optical Wavelength Converter

PAVEL ŠKODA, JOSEF VOJTĚCH, MIROSLAV KARÁSEK, TOMÁŠ UHLÁŘ,  
MILOSLAV HŮLA, STANISLAV ŠÍMA, JAN RADIL

Received 9.12.2009

### Abstract

We present a working sample of a wavelength converter with an photonic multicast option. The key prototype component is the commercial module from CIP Technologies. The device utilizes wavelength conversion in the interferometric scheme through cross phase modulation in a semiconductor optical amplifier. We tested conversion efficiency at 10 Gbps speeds, 40 Gbps tests will continue. Basic setup, alignment and performance measurements are described too.

*Keywords:* Optical Transmission, Photonic Network, Wavelength Conversion, Cross Phase Modulation, Mach-Zehnder Interferometer, XPM, MZI

## 1 Introduction

The main advantage of Dense Wavelength Division Multiplex (DWDM) transmission systems is in the simultaneous treatment of all wavelength channels, or lambdas. They are treated on the analog principle, thus showing the transparency for transmission speeds and modulation formats [1]. Systems are based on many different topologies starting from simple chain or ring topology to complicated topologies, e.g. rings of rings.

However as the capacity of transmission systems is exhausted and it is still more difficult to allocate a free lambda channel from start to end point, especially in complicated topologies. This situation is typically solved by optic-electric-optic conversion, which lacks transparency and is expensive for very fast signals, e.g. 40 Gbps or more.

The issue of wavelength change can be solved by introducing of all optical wavelength conversion. Many different principles have been proposed in the past, e.g. [2] or [3]. The most widespread is utilization of non-linear properties of Semiconductor Optical Amplifier (SOA) or non-linear optical fibre. The exploitation of SOAs offers simple integration and power amplification. We chose the Cross Phase Modulation (XPM) in SOA, where the interference setup is used to convert phase changes into the amplitude modulation. This conversion can produce more lambdas carrying the same information and can be used for the all optical multicast [4].

## 2 Conversion method

The conversion is based on the cross phase modulation phenomenon in the nonlinear medium of SOA. The converter consists of the Mach-Zehnder Interferometer (MZI) with SOA and phase shifter (PS) placed in both its arms according to Figure 1. MZI is balanced by phase shifters, without the presence of data signal. Phase

is tuned so that the continuous signal interferes destructively at the output of MZI. The intensity of data signal modulates the refractive index of the nonlinear medium of SOA that in response change the phase of co-propagating continuous signal on the new wavelength. The phase change in one arm MZI breaks interferometers balance and the phase modulation is converted to the amplitude modulation of continuous signal. The bit pattern of data signal is transferred to the continuous signal through the balancing of interferometer.

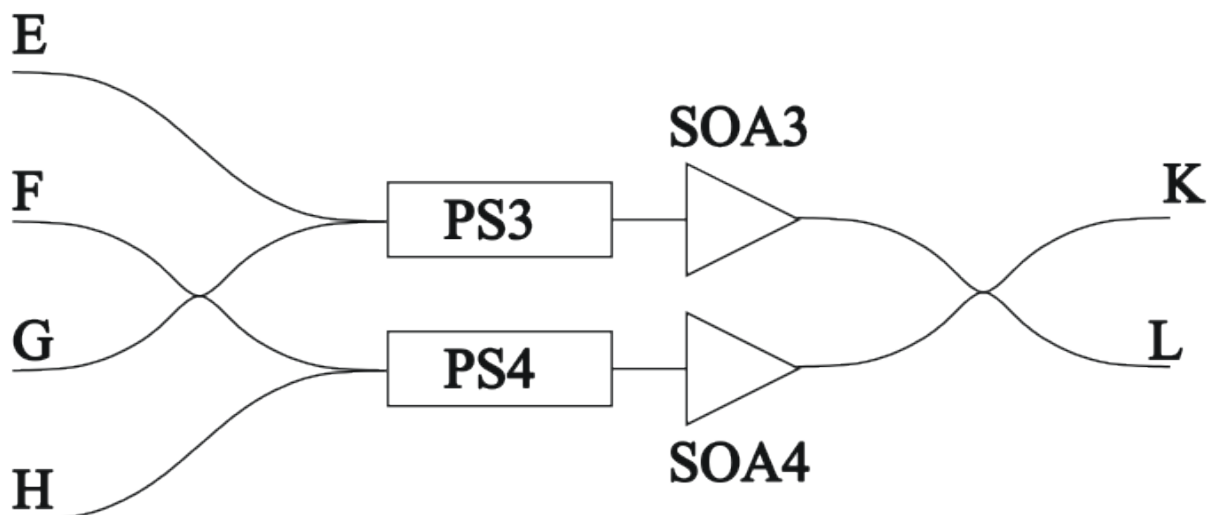

Figure 1. CIP Technologies chip

Table 1. The right power level setting for CW signal

Data wavelength (ITU channel) CW wavelength (ITU channel)	Level of CW signal [dBm]	Level of data signal [dBm]
1545,32 nm (22)	3	2
1543,73 nm (20)	2	0
	1,5	-2
	-1	-5
1550,12 nm (28)	6	2
1548,51 nm (26)	4	0
	2	-2
	-1	-5
1554,94 nm (34)	7	2
1553,33 nm (32)	4	0
	3,5	-2
	0	-5

### 3 Power setting of CW

Since the response of integrated SOAs on CIP chip is in order of tens of picoseconds, SOAs have to operate in the saturated regime to provide the uniform gain for 100 ps long data pulses. The gain saturation is achieved by a strong CW signal. The appropriate level of the CW signal depends on data signal level and wavelength. The convenient setting is gathered in Table 1 for three wavelengths and several levels of data signal. The right power level of CW signal is 2-6dB larger than data signal, when data signal level stays between -5dB and 2dB.

### 4 Setting up 10Gbps data conversion

For the conversion of 10Gbps non-return-to-zero (NRZ) signal a simple scheme was employed according to Figure 2. The temperature of CIP chip was stabilized to 20°C and SOAs were biased equally. Polarization controller PC4 and phase shifters PS3 and PS4 were used to balance MZI with extinction ratio better than 15dB. PC3 adjusted the polarization of incoming data signal. We used a long-reach DWDM XFP transceiver of 10Gbps NRZ signal and a clock recovery unit to obtain the eye diagram for conversion from 1550,12 nm to 1548,51 nm (2 ITU 100 GHz channels). Figure 3 displays the contrast between eye diagrams of transmitted and converted data. The eye diagram for converted signal is as open as for transmitted signal just a partially noisier, which stands for the low signal degradation during the conversion process.

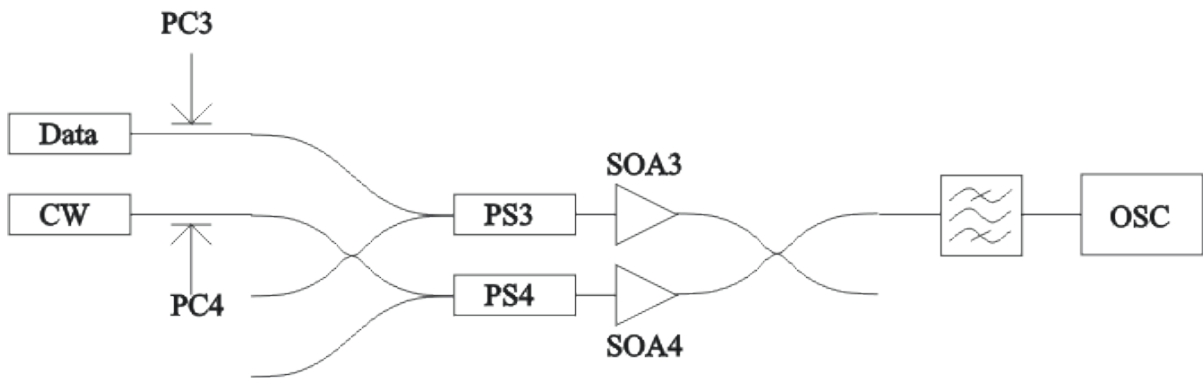
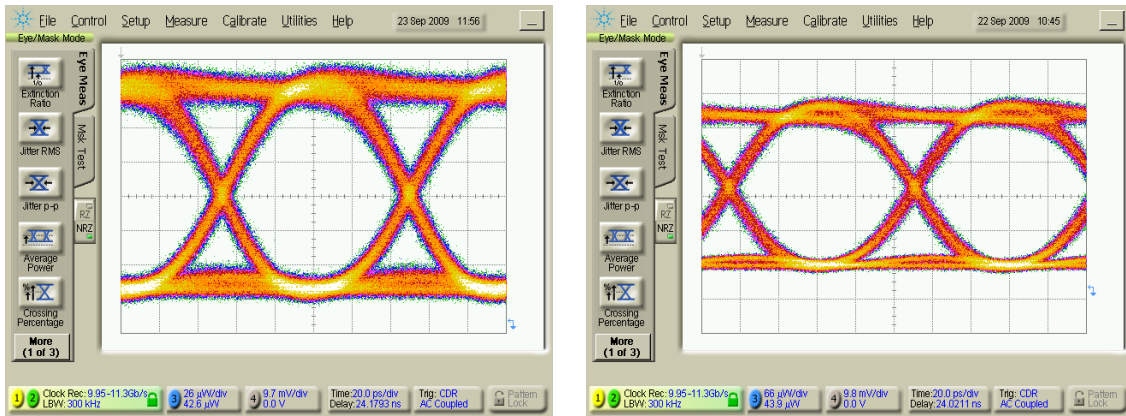

Figure 2. Conversion scheme for 10Gbps

### 5 Frame error rate test and eye diagram measurement

The bit error rate test characterizes device or link under test from the telecommunication point of view. Test tells us how strong should the signal be to allow transmitter-receiver pair works under the defined bit error rate. We used the  $2^{(23)}-1$  test pattern with the frame size of 64 bytes and performed each measurement for 32 minutes. This allow us to measure the frame error rate of transmitted frames down to  $10^{-11}$  with 95% confidence factor. BER tester counts the number of lost or badly received frames and compares it to number of transmitted frames to evaluate the



**Figure 3.** Eye diagrams of 10Gb/s NRZ (left) and converted NRZ signal (right).

frame error. We sent the converted signal through two fiber links and estimated frame error rate. First link was 125 km long SMF-TW with dispersion of about 4 ps/nm/km. Second link was 65,5 km long SMF-MC with dispersion of about 16 ps/nm/km. The dependence of frame error rate on the signal level is plotted in Figure 4. One can see that frame error rate increases exponentially with decrease in signal level and also increases for longer fiber link. We also measured eye diagrams for the converted signal propagating through several fiber links. The eye diagram shows the influence of wavelength converter and fiber link on the final signal shape. The transmission quality is limited by fiber chromatic dispersion and attenuation as can be seen in Table 2. Second and third row in Table 2 show the degradation of signal due to the chromatic dispersion. Attenuation in combination with chromatic dispersion play role in last three rows. The clock recovery unit was not able to lock on the signal after propagation through 63,5 km of SMF-MC fiber because of the accumulated dispersion.

## 6 Working sample details

The working sample offers user-friendly interface through mini-PC motherboard in combination with high quality optical components from CIP Technologies and Phoenix Photonics. Support electronics with twin power supply ensure reliability and long life of wavelength converter. Device has 2 optical inputs and one optical output. Converter was embedded in 2U IPC case according to Figure 5 to allow server-compatible accommodation.

2U case contains

- Two computer power sources from TDK-Lambda
- Mini mother board from EPIA
- Universal regulated adapter 120W from Vanson
- Twin Regenerator from CIP technologies
- Two polarization controllers from Phoenix Photonics
- Power source and TEC control designed by Adicom
- Support electronics and fiber optics

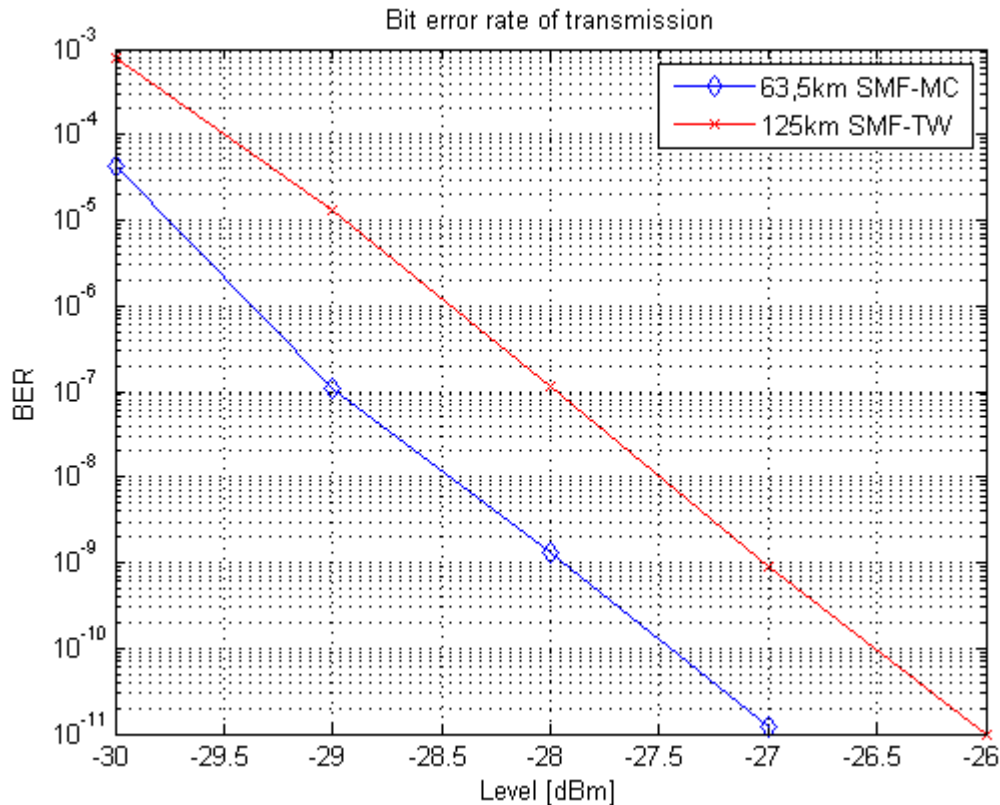

Figure 4. Bit error rate measurement for two fiber links.

## 7 Conclusion and future development

The wavelength converter is working for transmission rates of 10 Gbps with the low signal degradation. The device is based on the commercial module from CIP Technologies with the possible extension up to 40 Gbps. As next step we consider combination of wavelength converter with module with tunable laser sources and wavelength selective switch into the wavelength multicasting switch, upgrading the wavelength converter to 40Gbps and make use of the second part of CIP module.

## References

- [1] DESUVIRE, E. *Erbium-Doped Fiber Amplifiers – Principles and Applications*. John Wiley & Sons, 1994.
- [2] DURHUUS, T. at al. All-Optical Wavelength Conversion by Semiconductor Optical Amplifiers, *Journal of Lightwave Technology*, Vol. 14, June 1996, p. 942–954.
- [3] YOO, S.J.B. Wavelength conversions Technologies for WDM Network Application. *Journal of Lightwave Technology*, Vol. 14, June 1996, p. 955–966.
- [4] KARÁSEK, M.; VOJTĚCH, J.; RADIL, J., Multicasting at 10Gb/s and 40GHz Using a Hybrid Integrated SOA Mach-Zehnder Interferometer. In Proceedings OFC 2009.

**Table 2.** Eye diagrams of conversion over 2 ITU channels measured after fiber links

10 km SMF-MC (~16ps/nm/km)

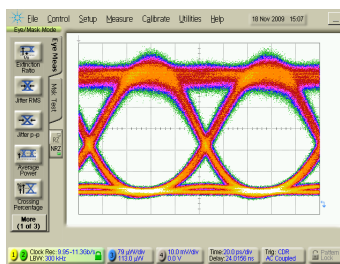

27,5 km SMF-MC (~16ps/nm/km)

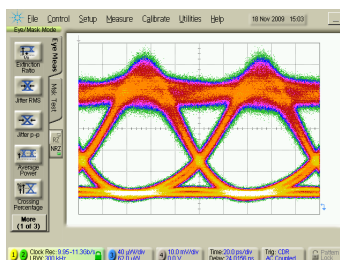

25 km SMF-TW (~4ps/nm/km)

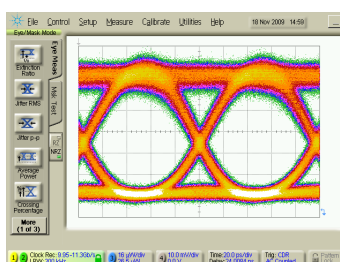

100 km SMF-TW (~4ps/nm/km)

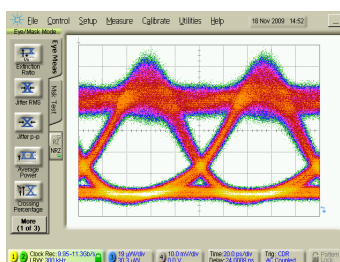

63,5 km SMF-MC (~16ps/nm/km)

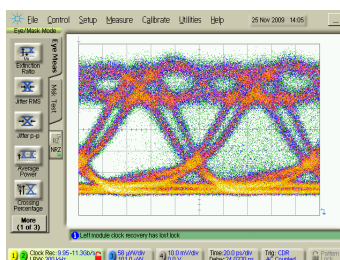

125 km SMF-TW (~4ps/nm/km)

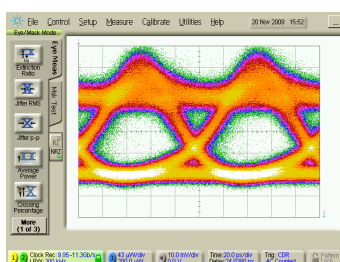

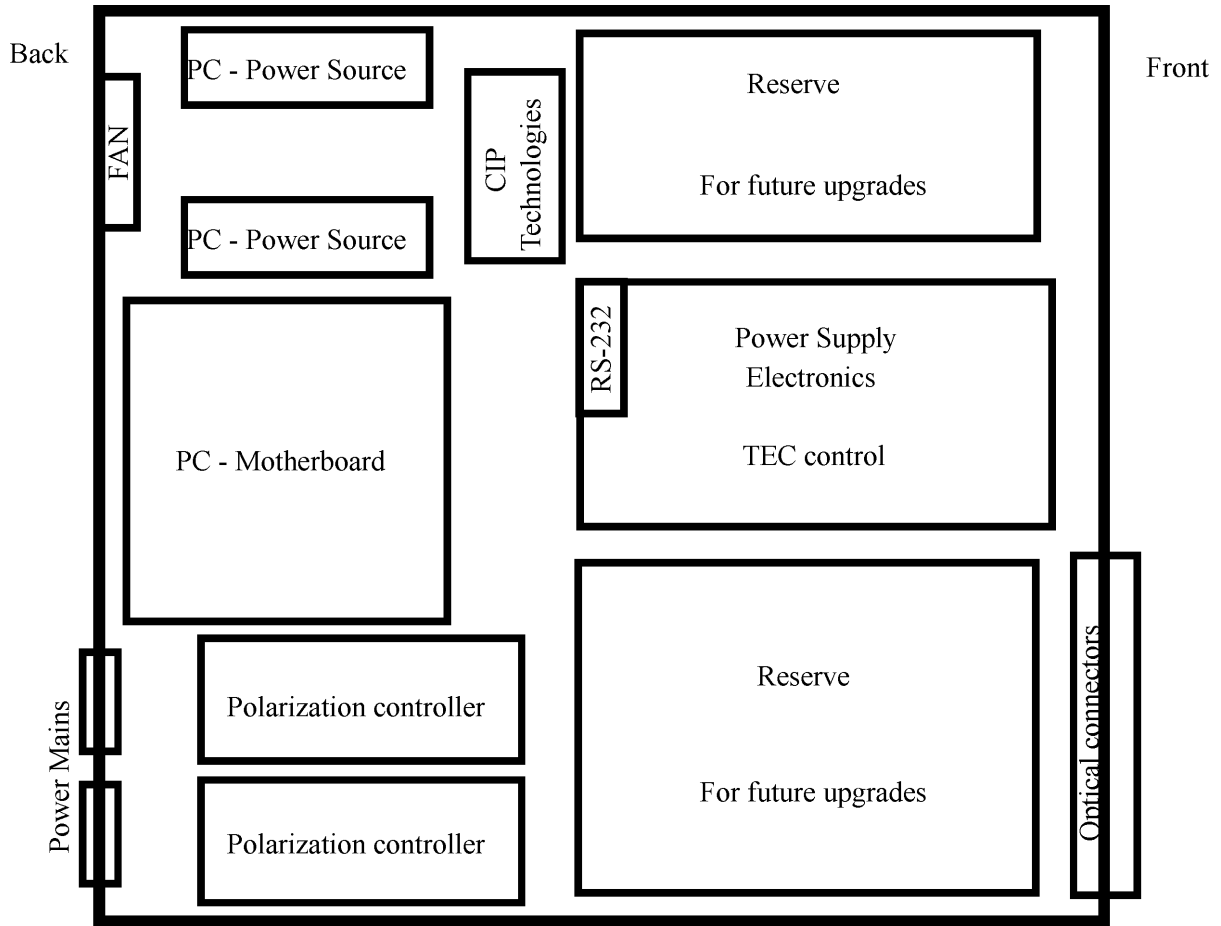

Figure 5. Prototype design in 2U case